

PX 200

- **accurate parallel motion in one direction because of parallelogram principles**
- **easy adjustment**
- **motion without any mechanical play because of solid state hinges**
- **integrated lever transmission**
- **motion up to 200 µm**
- **easily combined with other piezoelectrical systems (especially xy and tilting systems)**
- **easily combined with mechanical positioning systems precision pin holes for accurate adjustment**

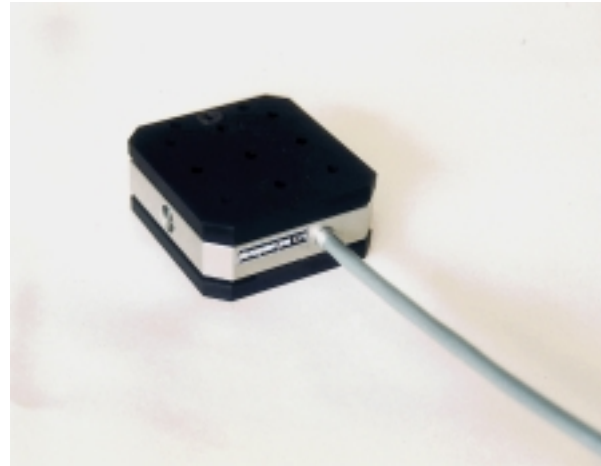

Due to the nature of the solid state flexure and parallelogram construction, the travel of these stages is without mechanical play in the x or z axes. A much higher resolution, achievable with mechanical or electromechanical systems, is possible. The PX series stages can be easily combined with xy and tilting piezoelectric modules to give positioning in all degrees of freedom.

The PX stages can be equipped with measurement systems that overcome the effect of hysteresis. Dynamic work of the elements is possible.

specifications:

operating voltage: -20 to +130 V
temperature range: -20 to 80 °C
housing: functional parts made from stainless steel
top and bottom plate aluminium anodised
connector: LEMO
cable length: 1 m

options:

- integrated measurement system (strain gauge; capacitive measurement system)
- vacuum / low temperature version
- high load version
- other modifications available on request

recommended supply:

NV 40/3; ENV 40; 12V40

piezosystem jena GmbH

Prüssingstraße 27 • 07745 Jena • HRB Gera 2823 • VAT ID-Nr. DE 150531409

Konten: Commerzbank BLZ 820 400 00, KTO 258 420 9 • Deutsche Bank BLZ 820 700 24, KTO 531 5718

Tel. + 49 (3641) 66 88 0 • Fax +49 (3641) 66 88 66 • e-Mail info@piezोजना.com •

<http://www.piezोजना.com/>

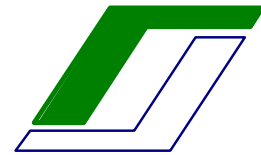

series PX part no.	unit	PX 38 T-101-00	PX 100 T-104-00	PX 200 T-106-00	PX 300 T-107-00	PX 400 T-108-00
motion ($\pm 10\%$)**	μm	38	100	200	300	400
max. load****	N	100	100	10	10	10
max. voltage	V	150	150	150	150	150
capacitance each direction***	nF	600	1800	1800	2500	5200
resolution open loop*	nm	0.07	0.18	0.37	0.56	0.75
resonant frequ. without add. mass	Hz	760	790	177	177	200
stiffness	N/ μm	1	1	0.08	0.08	0.16
force generation (blocking force)	N	30	100	16	24	64
dimensions length L	mm	25	40	52	52	52
width B	mm	25	40	48	48	48
height H	mm	18	20	20	20	20
holes for precision pins N	mm	$\varnothing 2\text{G7} \times 3$	$\varnothing 3\text{G7} \times 3$	$\varnothing 3\text{G7} \times 4$	$\varnothing 3\text{G7} \times 4$	$\varnothing 3\text{G7} \times 4$
K	mm	9.5	16	18	18	18
J	mm	10	5	9	9	9
hole pattern spacing C	mm	20	32	32	32	32
thread M	mm	M2 x 4	M3 x 5	M3 x 4	M3 x 4	M3 x 4
thread P	mm	$\varnothing 2.2 / \varnothing 4 \times 12$	$\varnothing 3.3 / \varnothing 6 \times 18$			
rotational error ϑ_x	μrad	10	10	10	10	10
ϑ_y	μrad	10	10	10	10	10
ϑ_z	μrad	10	10	20	20	30
mounts directly to	-	PXY 38 PZ 38 TRITOR 38	PXY 100 PZ 100 TRITOR 100	PX 400 PX 300 PX 200	PX 400 PX 300 PX 200	PX 400 PX 300 PX 200
weight	g	40	85	175	175	175
connector voltage	-	LEMO	LEMO	LEMO	LEMO	LEMO
series PX with integrated measurement system part no.	unit	PX 38 SG T-101-01	PX 100 SG T-104-01	PX 200 SG T-106-01	PX 300 SG T-107-01	PX 400 SG T-108-01
motion** open loop	μm	38	100	200	300	400
closed loop	μm	32	80	160	240	320
repeatability	nm	23	29	36	62	75
non-linearity	%	0.1	0.8	0.06	0.20	0.09
dimensions length L	mm	40	40	52	52	52
width B	mm	40	40	48	48	48
height H	mm	25	20	22	22	22
weight	g	77	85	180	180	180
connector sensor	-	LEMO 0S.304	LEMO 0S.304	LEMO 0S.304	LEMO 0S.304	LEMO 0S.304
series PX with integrated measurement system part no.	unit	-	PX 100 CAP T-104-06	PX 200 CAP T-106-06	PX 300 CAP T-107-06	PX 400 CAP T-108-06
motion** open loop	μm	-	100	200	300	400
closed loop	μm	-	80	160	240	320
resolution open loop	nm	-	0.18	0.37	0.56	0.75
closed loop	nm	-	1	1	1	1
repeatability	nm	-	15	13	18	38
non-linearity	%	-	0.05	0.036	0.035	0.042
dimensions length L	mm	-	40	52	52	52
width B	mm	-	40	48	48	48
height H	mm	-	29	20	20	20
weight	g	-	85	180	180	180
connector sensor	-	-	LEMO 0S.650	LEMO 0S.650	LEMO 0S.650	LEMO 0S.650

* measured with E-103-18 amplifier

** typical value measured with -20V to 130V

*** typical value for small electrical field strength

**** also available as high load version

piezosystem jena GmbH

Prüssingstraße 27 • 07745 Jena • HRB Gera 2823 • VAT ID-Nr. DE 150531409

Konten: Commerzbank BLZ 820 400 00, KTO 258 420 9 • Deutsche Bank BLZ 820 700 24, KTO 531 5718

Tel. + 49 (3641) 66 88 0 • Fax +49 (3641) 66 88 66 • e-Mail info@piezोजना.com •

<http://www.piezोजना.com/>

motion →

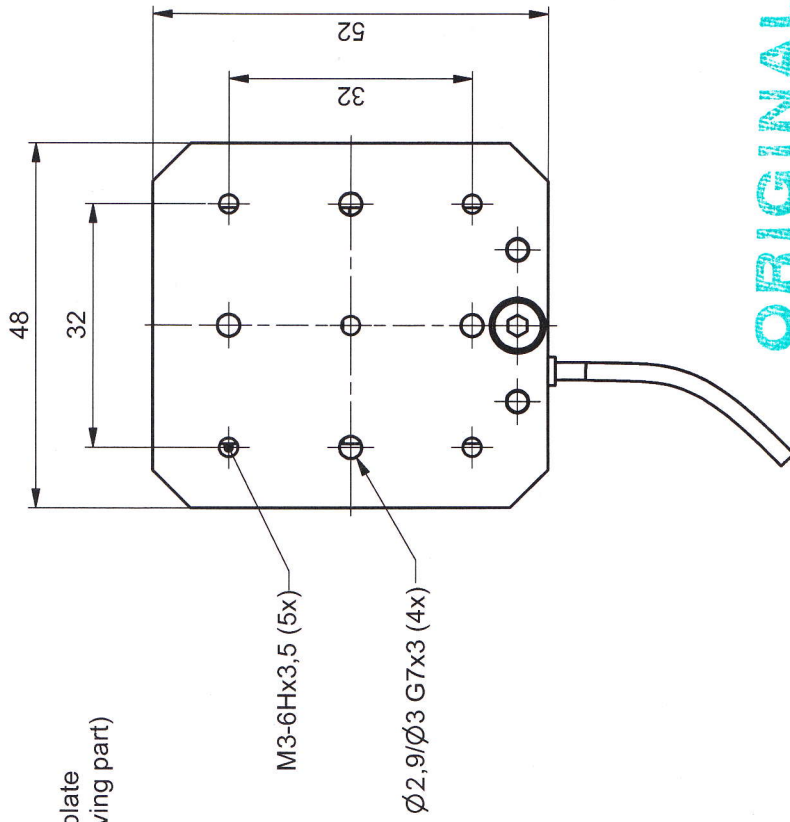
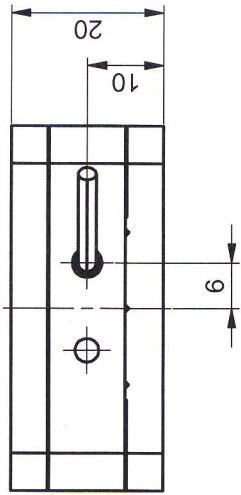

ORIGINAL

bottom plate
(fixing part)

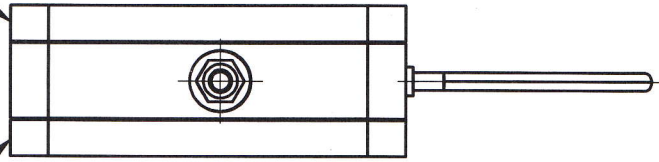

top plate
(moving part)

M3-6Hx3,5 (5x)
Ø2,9/Ø3 G7x3 (4x)

nomenclature:

X	model	part no.
6	PX200	T-106-00
7	PX300	T-107-00
8	PX400	T-108-00

standard cable length 1000 mm

part.-no.	T-10X-00	part.-name	PX 200/300/400
file name	PT10X00	OK: date/sign.	13. MRZ. 2012
		scale	1:1
		customers drawing	

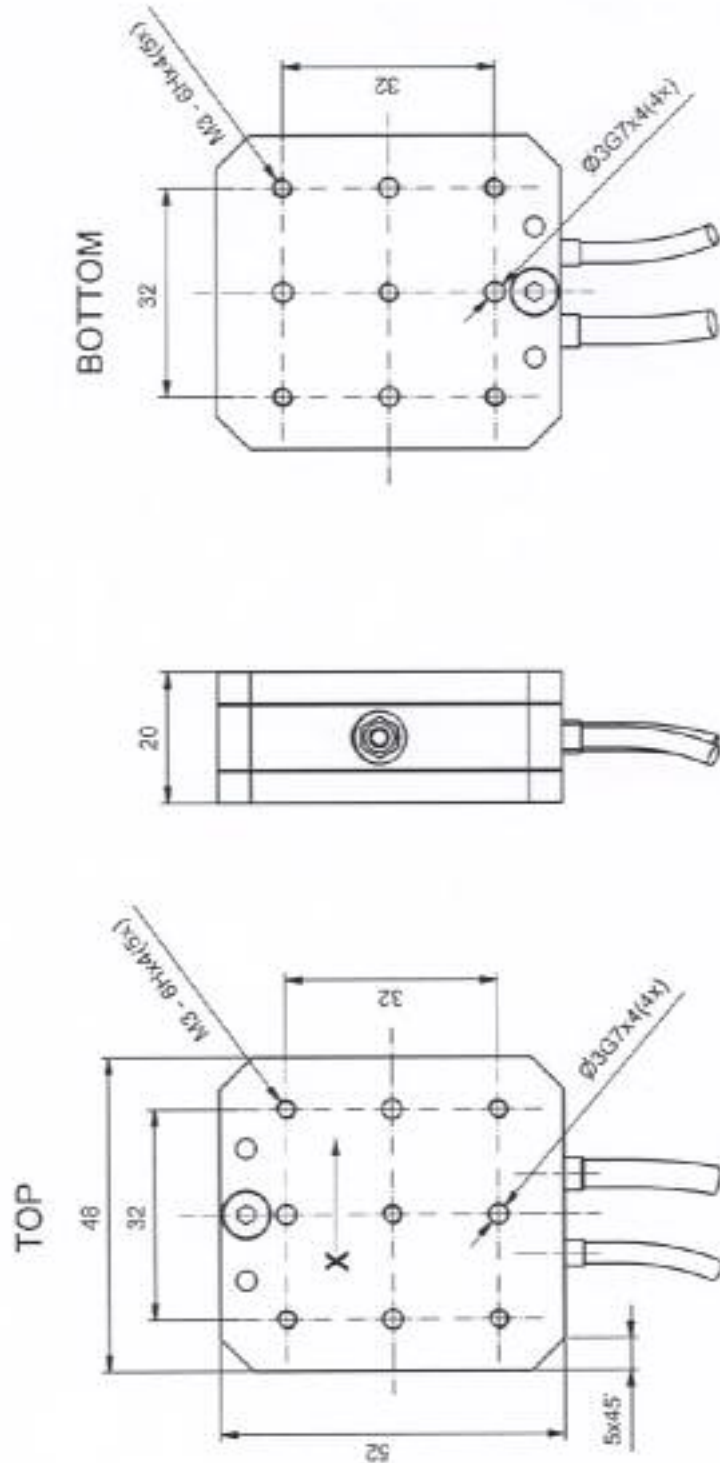

Changed height! From 22mm to 20mm

Zeichnung auch gültig für:
(drawing relevant for:)
T-106-01 PX200SG
T-107-01 PX300SG

part-no	part-name	date	customer drawing
T-108-01	PX400SG	16. FEB. 2008	piezosystem jena
3rd name	OK date/sign.		
PT10801			
scale		1:1	

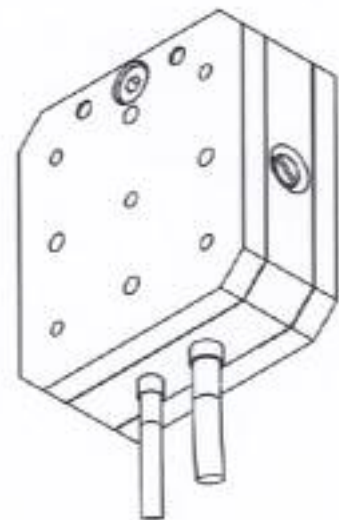

ORIGINAL

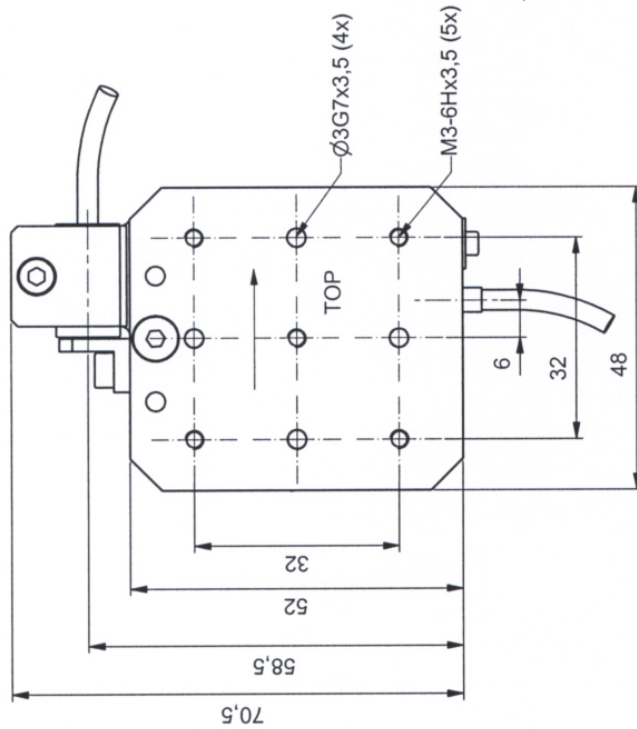
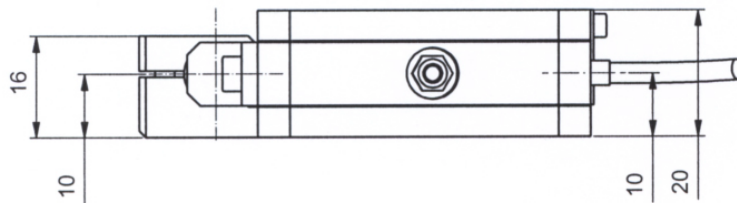
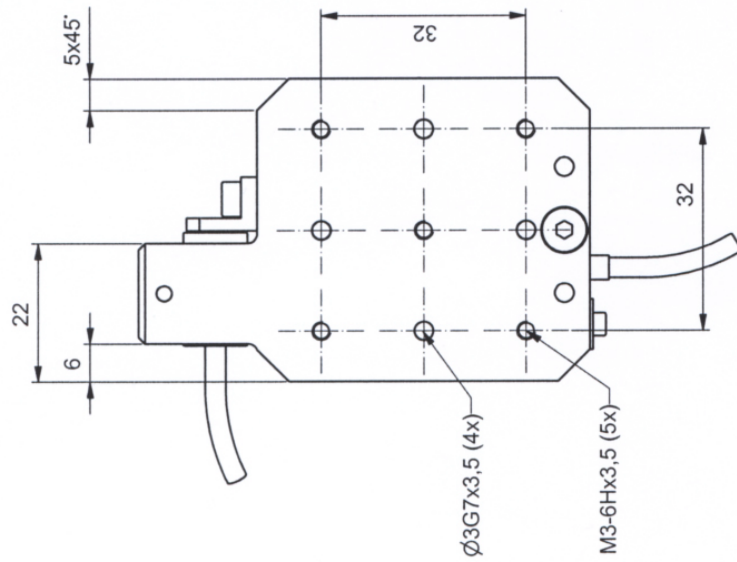

This drawing is valid for following systems as well:

- PX300 CAP (part.-no. T-107-06)
- PX200 CAP (part.-no. T-106-06)

part.-no.	part.-name	scale
T-108-06	PX400 CAP	1:1
file name	OK: date/sign.	customers drawing
PT10806	24. JULI 2006	piezosystem jena

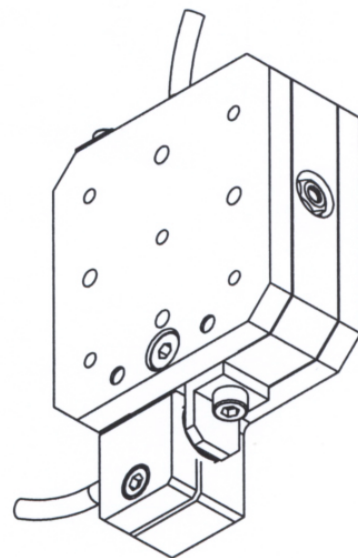

ORIGINAL